

RSOD 04014 7/0

AMALGAM VIRGO 02

TECHNICAL STUDIES AND ANALYSIS CORP

28 JUNE 2002

BRIEFER: CARL HOWELL

THIS BRIEFING IS

UNCLASSIFIED

NCT0066544

AV02 OVERVIEW

- **INTRODUCTION**
- **EXERCISE TIMELINE**
- **TSA OBSERVATIONS**
- **PROPOSED JULLS**

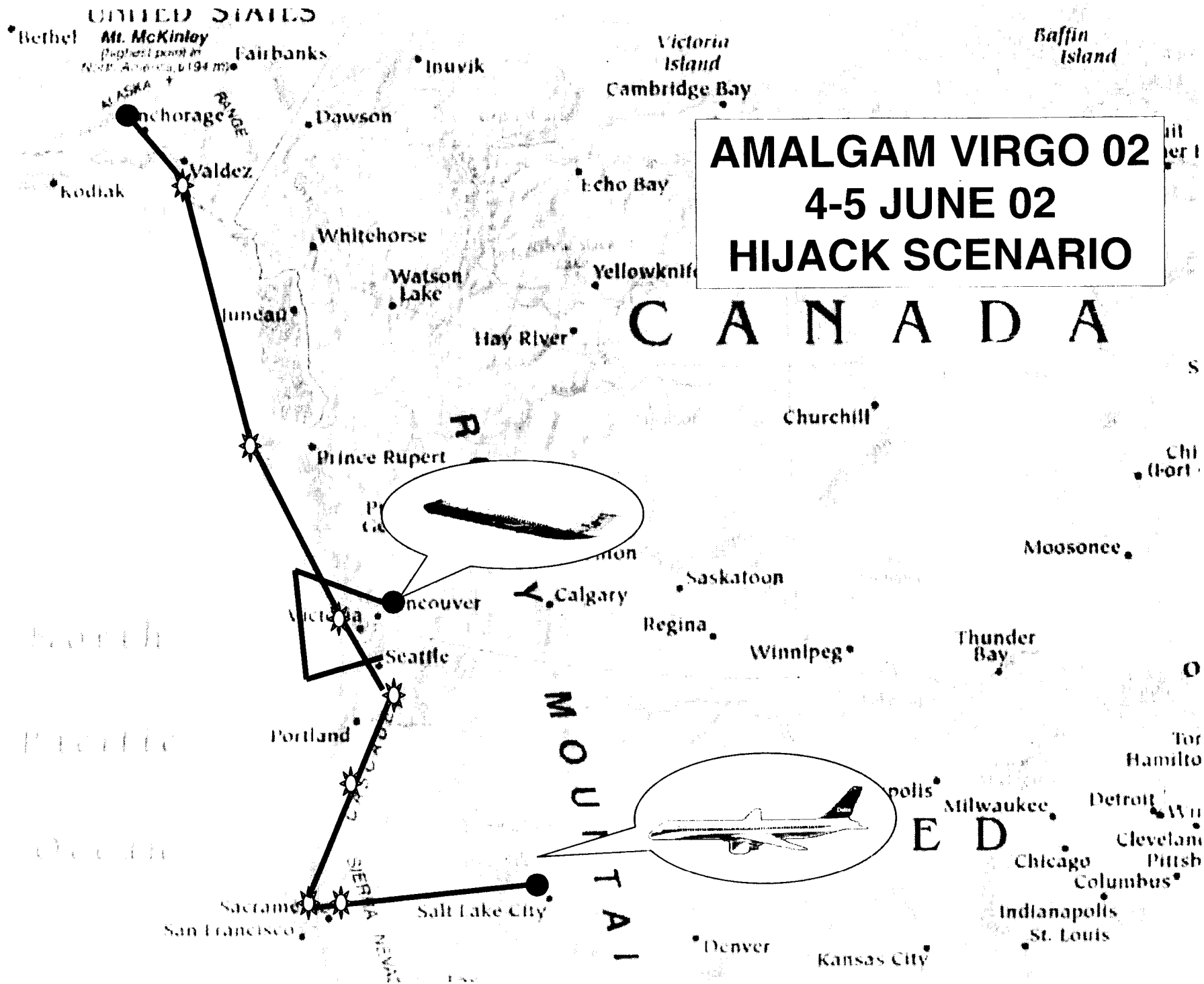

NCT0066546

AV02

INTRODUCTION

- **OBSERVERS AND LOCATIONS**
 - **ALLEN NASH & MEL MCMULLIN**
 - **CMOC N-SP/CC, AWC, & J2 BATTLE CAB**
 - **CARL HOWELL**
 - **CANR BATTLE STAFF & AOC**

- **TSA PREPLANNED OBSERVATION AREAS**
 - **NOBLE EAGLE DOMESTIC EVENT/THREAT CONFERENCES**
 - **RULES OF ENGAGEMENT**
 - **HIJACK PROCEDURES**
 - **INTERAGENCY COORDINATION**
 - **US/CANADIAN CROSS BORDER COORDINATION**

AV02

EXERCISE DESIGN, DEVELOPMENT, AND CONTROL

“TOP NOTCH”

AV02

TIMELINE

- **NORAD PERSPECTIVE ONLY**
 - **NO ON-BOARD OBSERVATIONS**
 - **NO GROUND OBSERVATIONS**
- **HIGHLIGHTS MAIN EVENTS**

AV02

PRE-EXERCISE

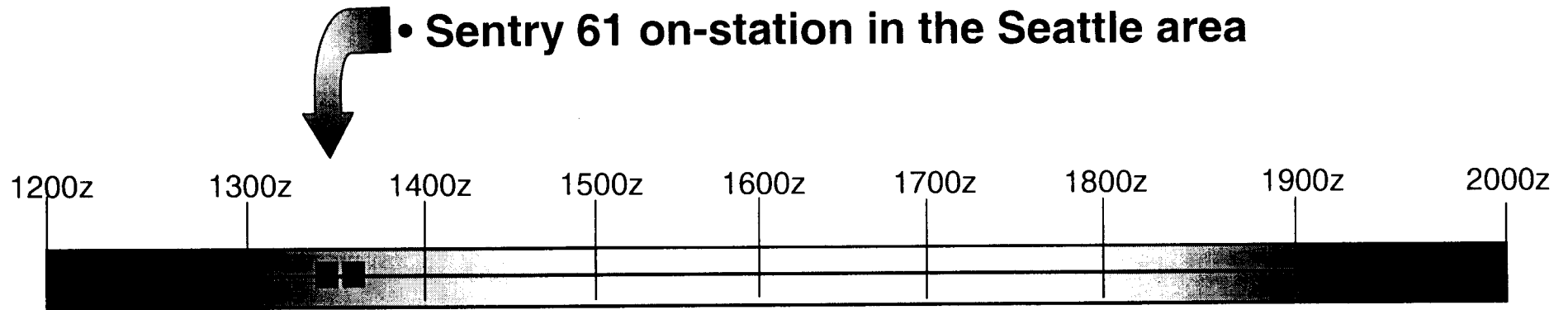

• Sentry 61 on-station in the Seattle area

1320Z 1330Z

• Fresno F-16s airborne for random city CAP

AV02

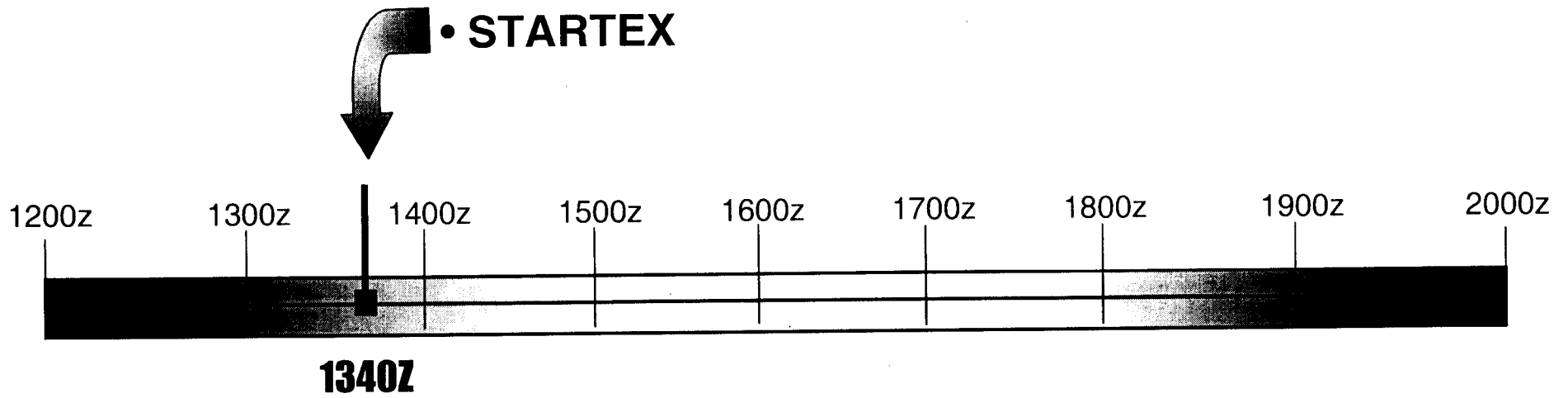

- The exercise start was delayed 40 minutes
- No observed problems with subsequent MSEL injection timing

AV02

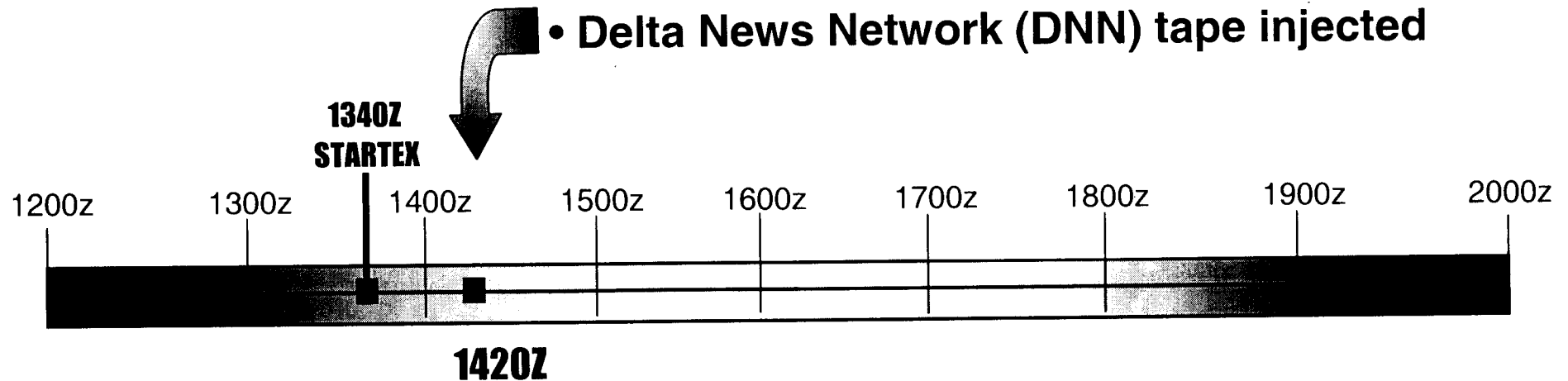

- Delta News Network (DNN) tape injected
- 1340Z STARTEX
- 1420Z
- First indication of a Hijack in progress
- No reports through the FAA or Military channels
- A Delta Passenger calls wife, and reports the Hijack

AV02

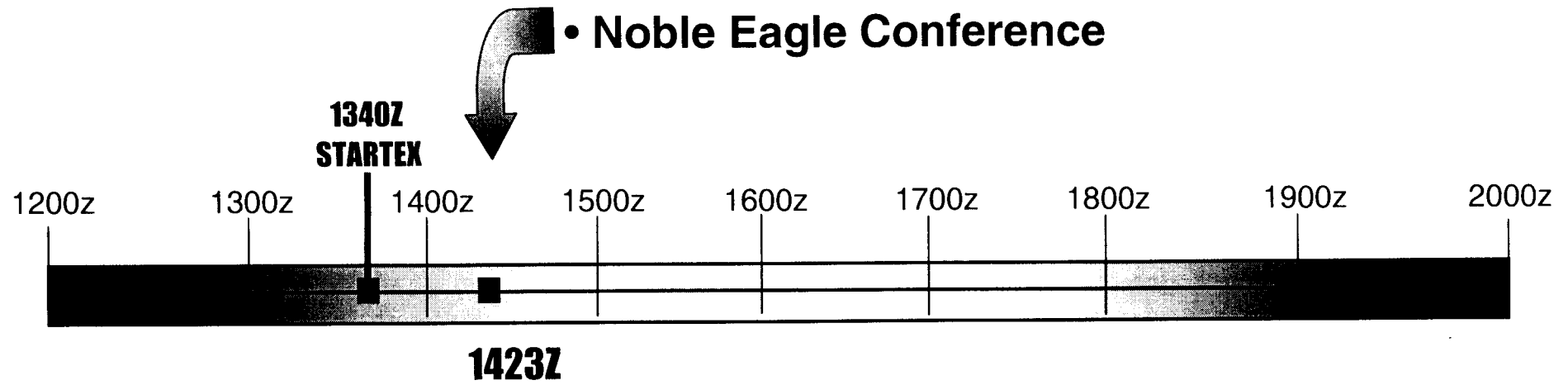

- Convened at the direction of the N-SP/CC Command Director in response to the DNN broadcast

AV02

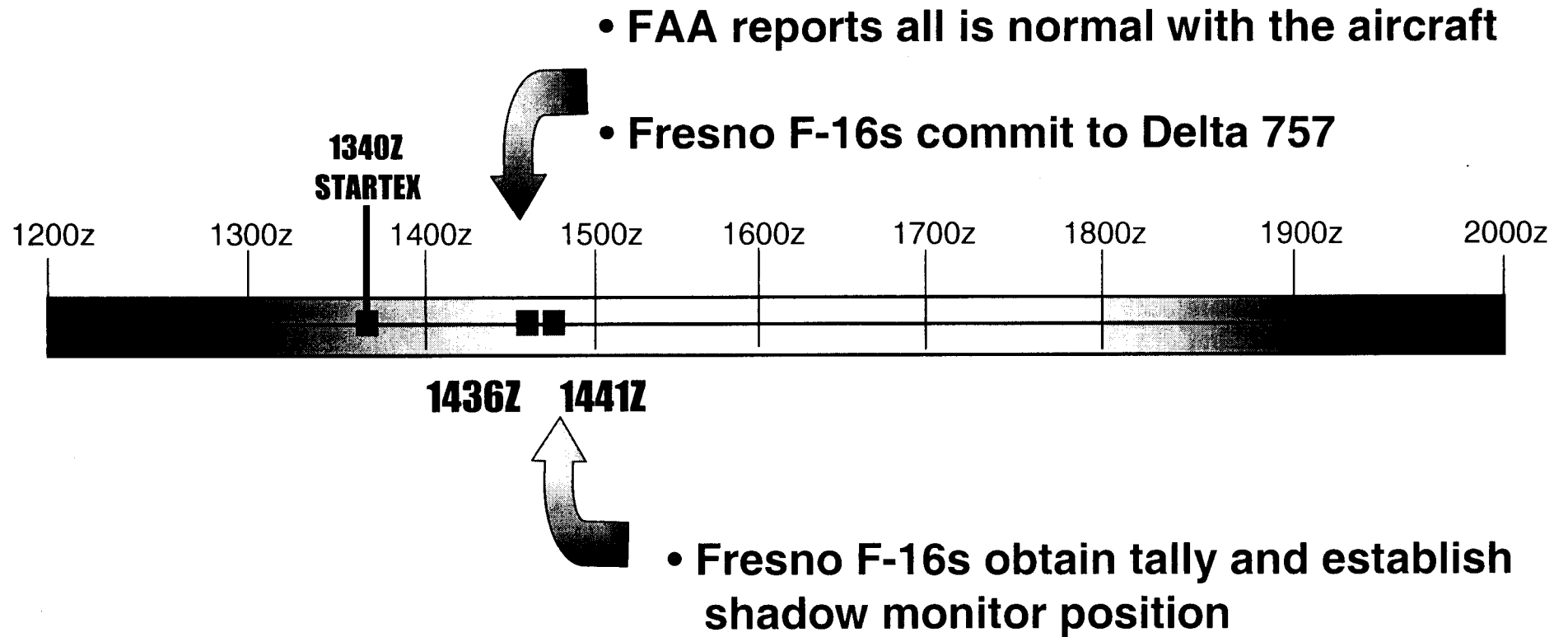

AV02

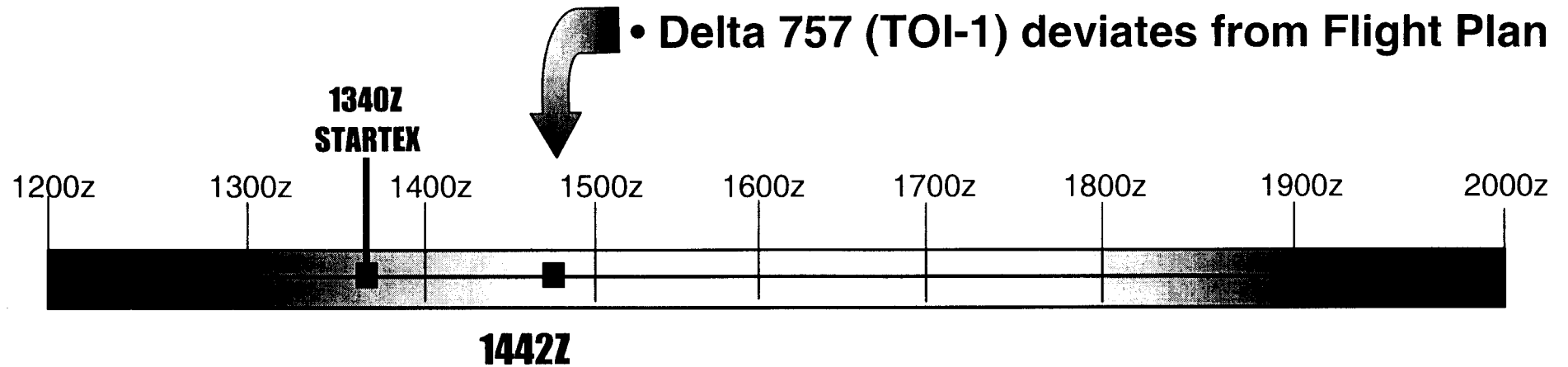

- FAA reports losing radio contact
- CONR recommends a DEC, NORAD concurs

AV02

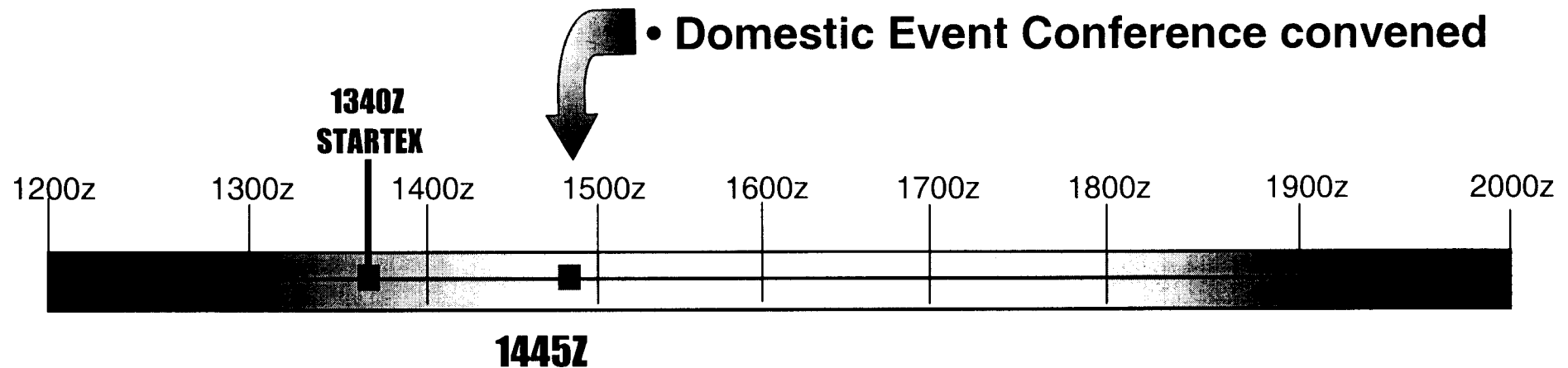

- CMOC ABMO Recap:
- A Delta Passenger calls wife, and reports being Hijacked
- Delta (TOI-1) deviates from Flight Plan
- FAA reports no communication with the airline flight crew
- FAA reports Mode III squawk as assigned
- NORAD fighters (Fresno F-16s) shadow monitor

AV02

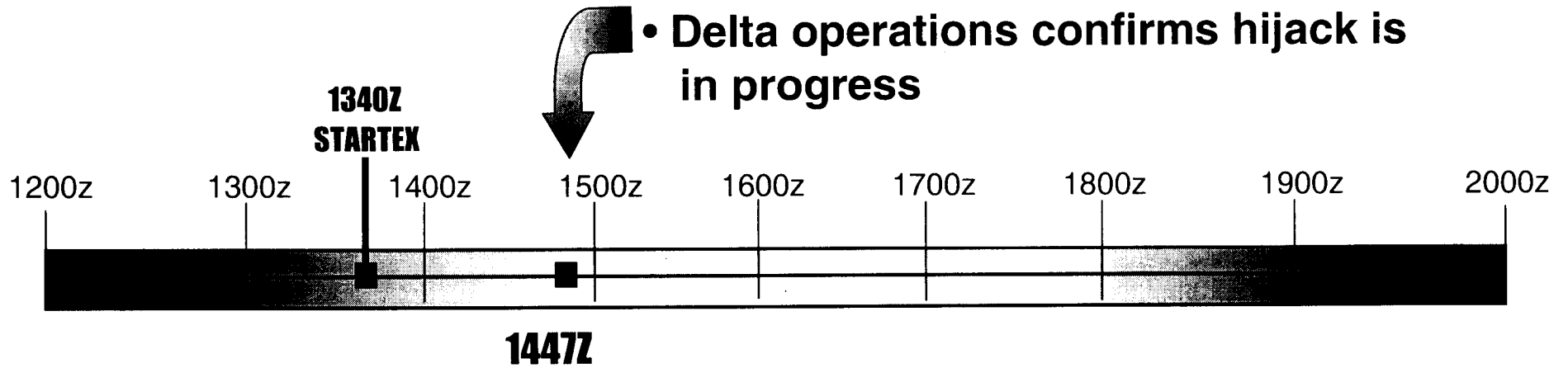

AV02

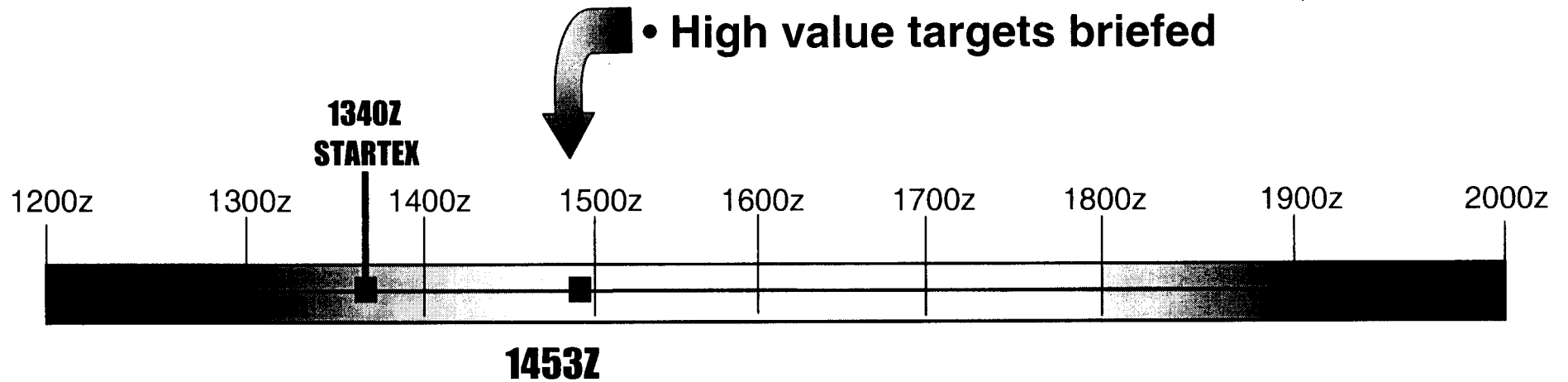

- Grand Coulee Dam
- Umatilla Chemical Depot
- Hanford Nuclear Plant

AV02

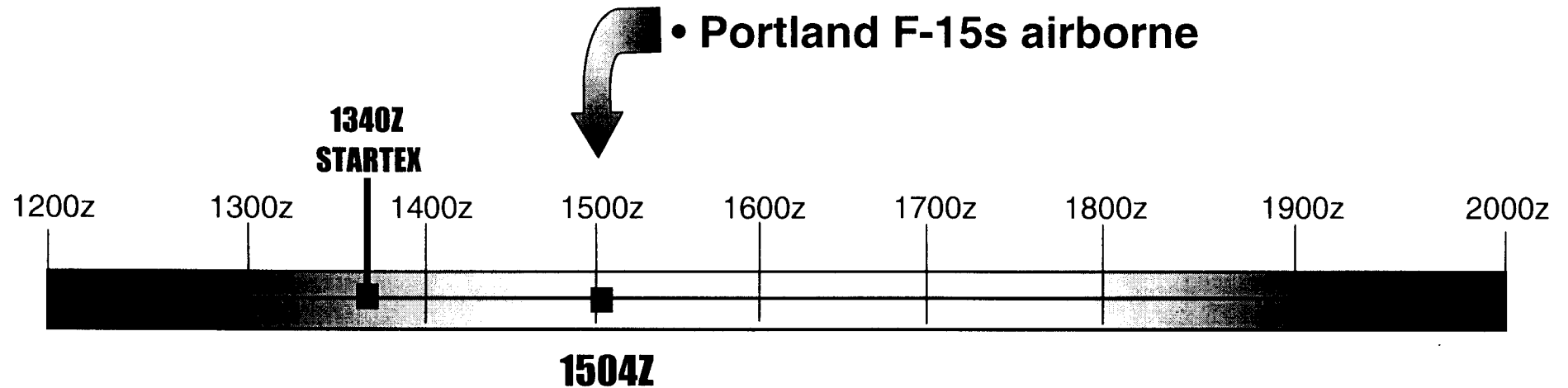

- Fresno F-16s VID as B767, cleared overt on Delta 757 (TOI-1)
- Sim CINCNORAD enters the conference
- JFACC not available
- Umatilla designated as priority target at 1509Z

AV02

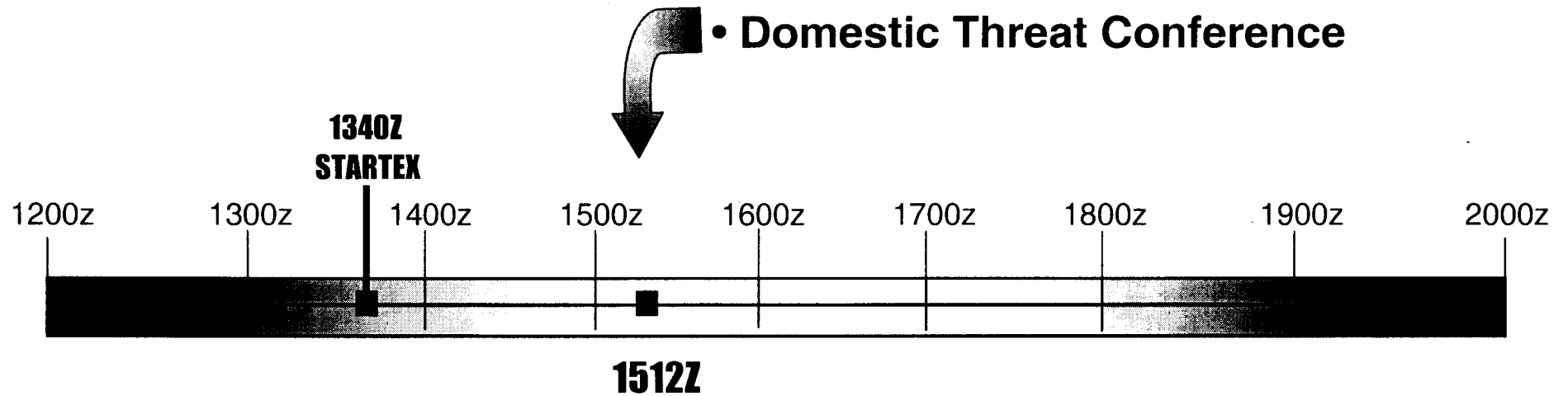

- FAA receives Hijackers demands
- NMCC DDO recommends a Domestic Threat Conference, NORAD concurs

AV02

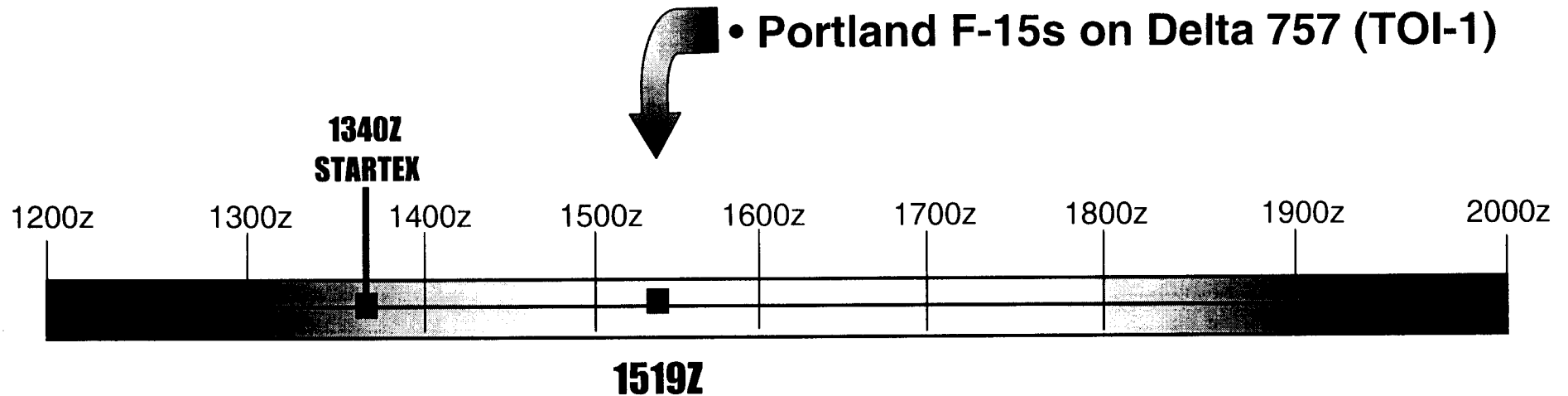

- Portland F-15s join with Fresno F-16s on Delta 757 (TOI-1)
- CONR directs Portland F-15s to establish visual contact with the cockpit
- E-3 TACON to WADS

AV02

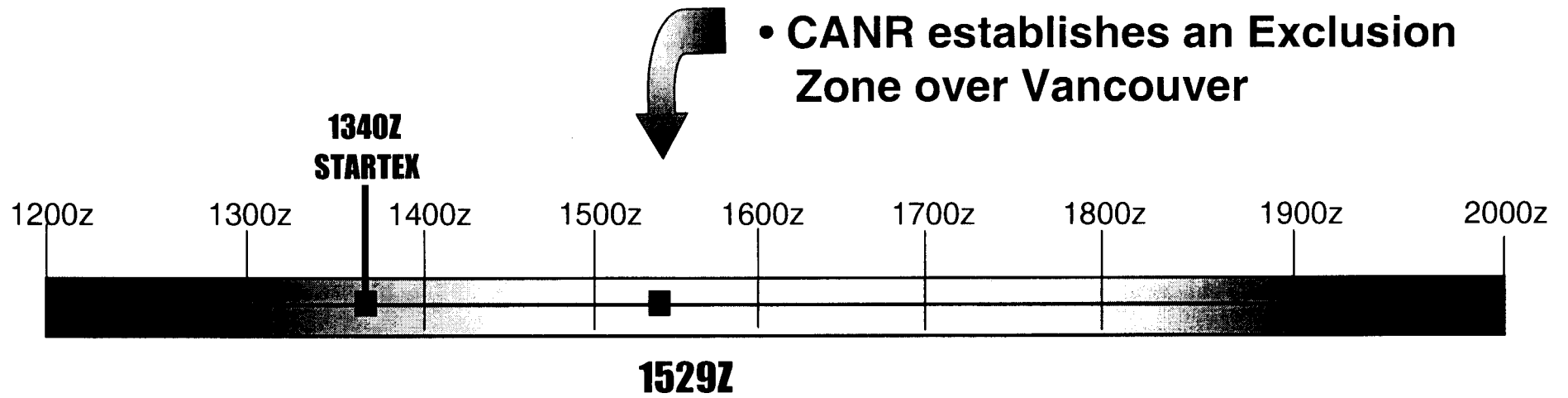

AV02

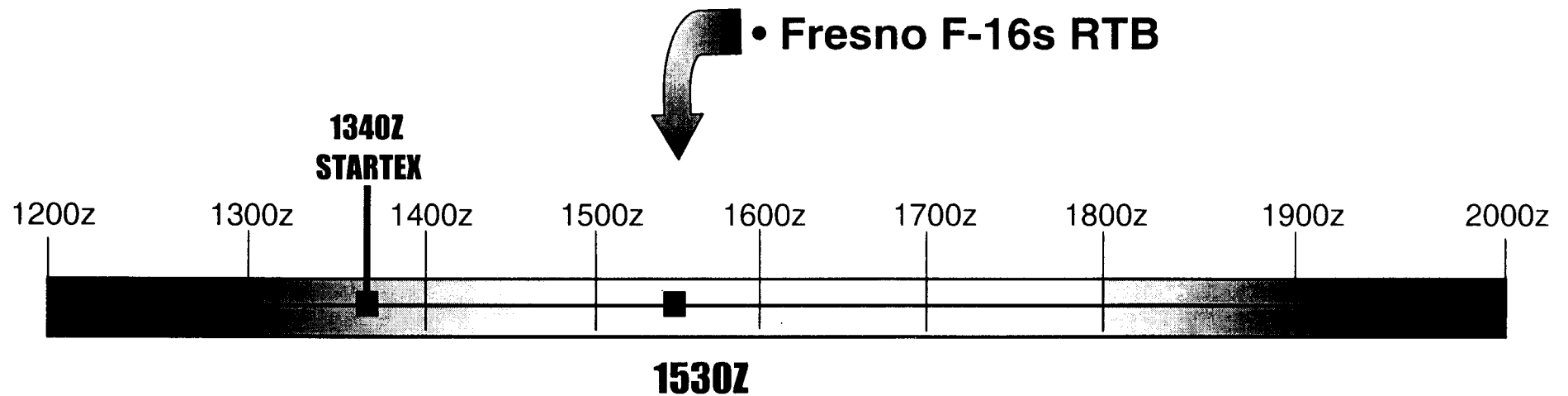

- Portland F-15s continue escort of Delta 757 (TOI-1)
- Great Falls F-16s establish CAP over Grand Coulee Dam
- 4 COMOX CF-18s (2 X ABO, 2 X RPI)

AV02

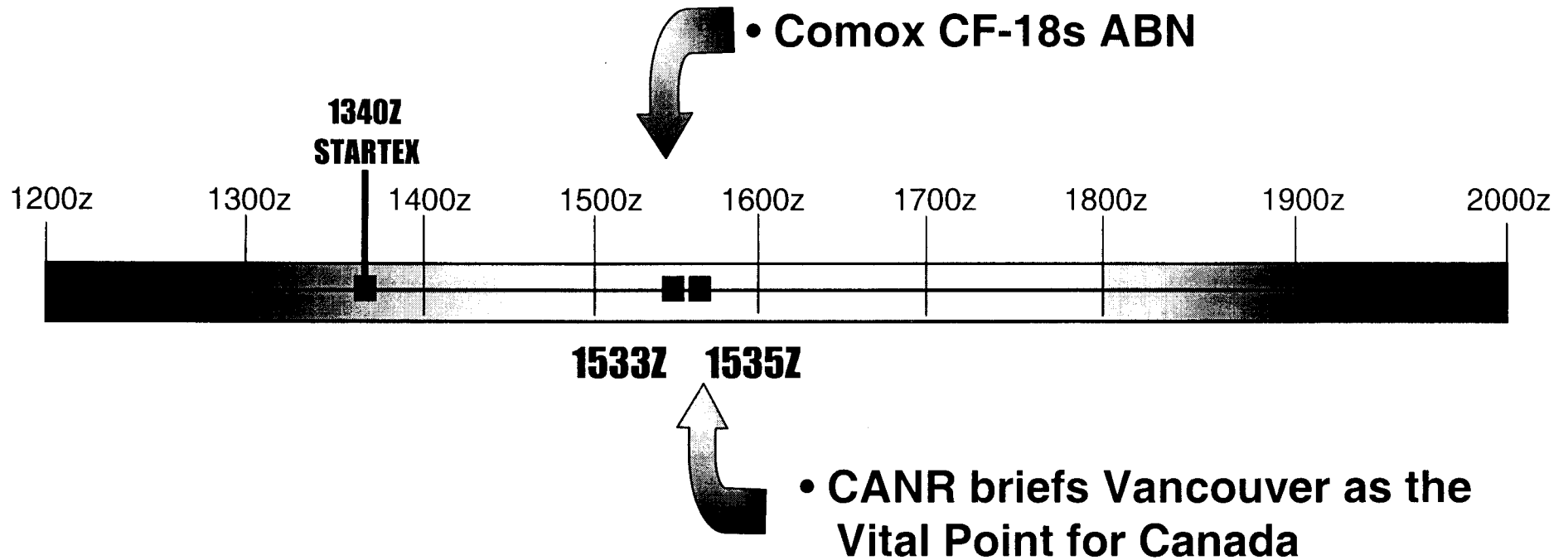

NCT0066564

- Comox CF-18s ABN for border CAP
- CF-18s delayed in Vancouver AOR by NAVCAN
- Departed Vancouver AOR for CAP at 1617Z

AV02

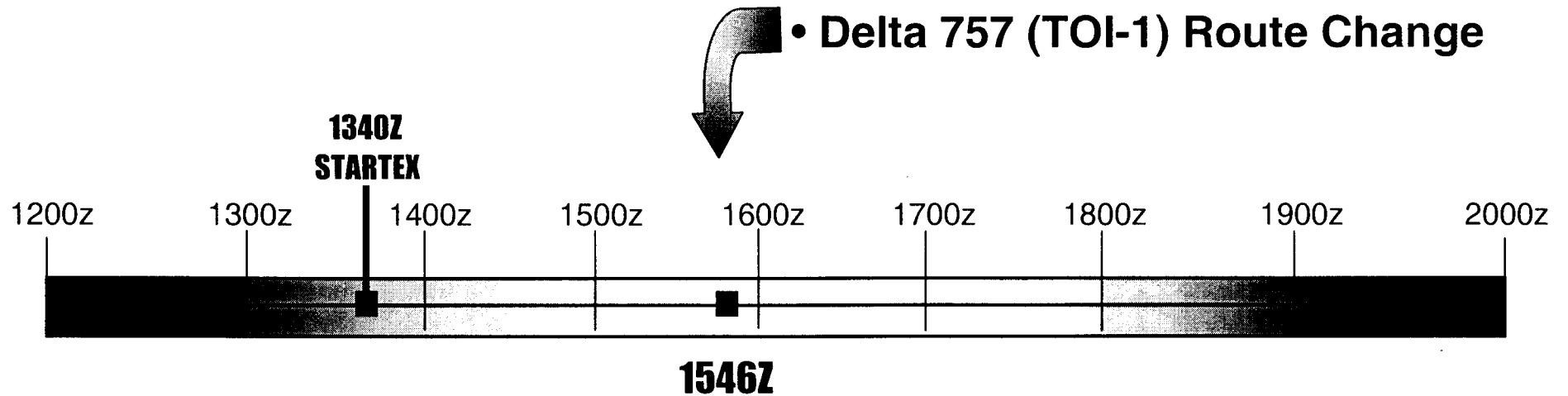

• Delta 757 (TOI-1) Route Change

- Hijackers direct the Delta aircrew to fly toward Seattle
- Great Falls F-16s moving CAP closer to Seattle
- New route will overfly Umatilla

AV02

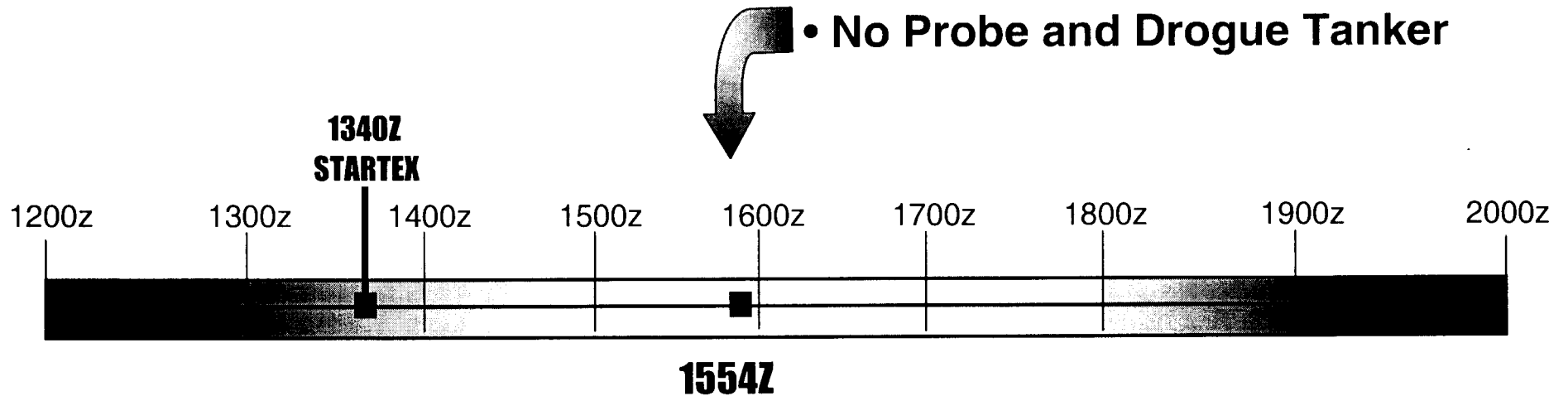

• No Probe and Drogue Tanker

- The Probe and Drogue tanker briefed as being airborne for CANR was boom equipped for U.S. fighters
- The Probe and Drogue tanker is still at Fairchild AFB with an ETIC of 1555
- Comox fighters playtime 1+50

AV02

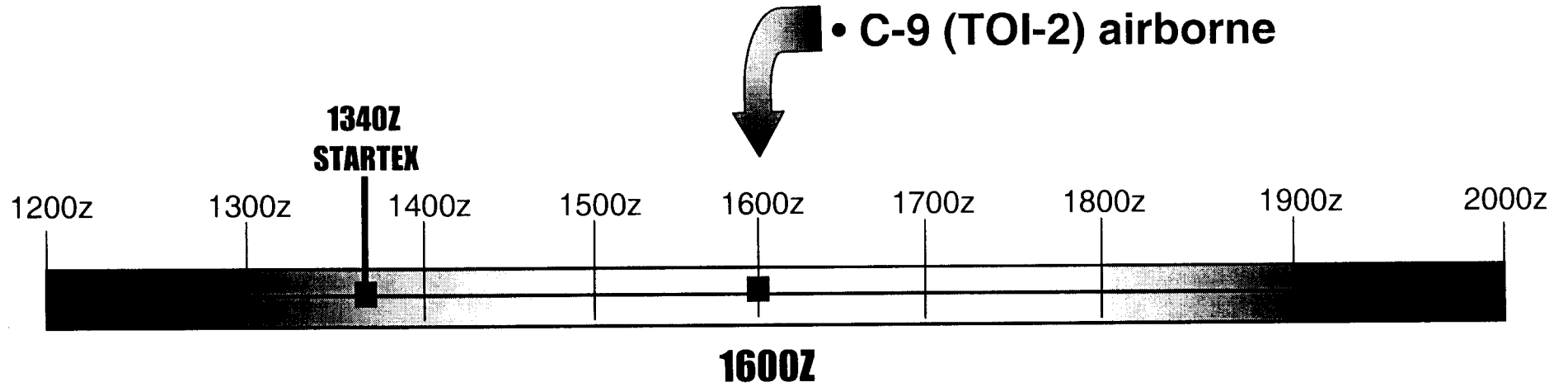

- TOI-2 airborne out of Whidbey Island

AV02

- Senior Decision Makers Discuss Cross-Border plans

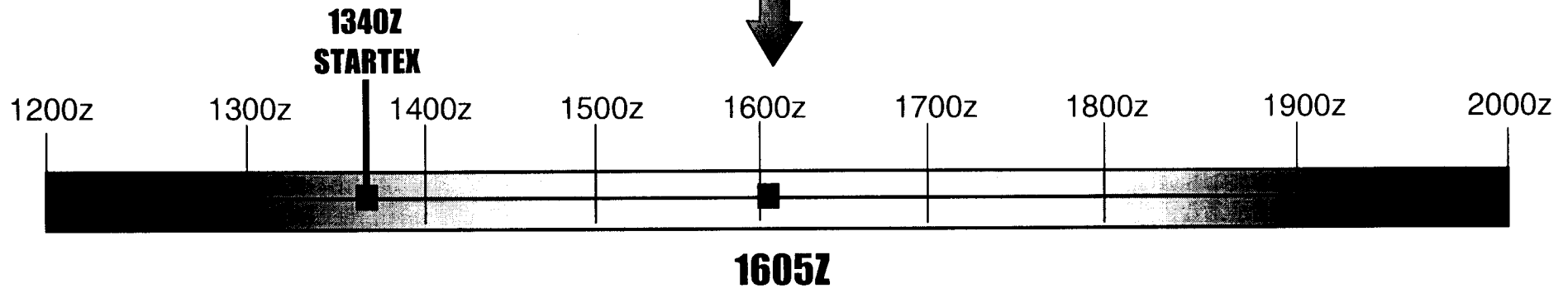

- SIM CINC approves US fighters to enter CANR airspace (if required)

AV02

- Probe and Drogue Tanker Airborne for Comox CF-18s

1340Z
STARTEX

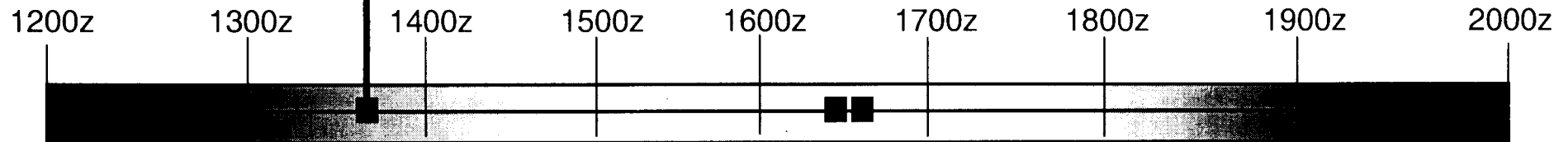

1621Z 1624Z

- Unconfirmed report of Sarin Gas on the Delta 757 (TOI-1)
- At 1804Z, this report was determined to be a hoax

AV02

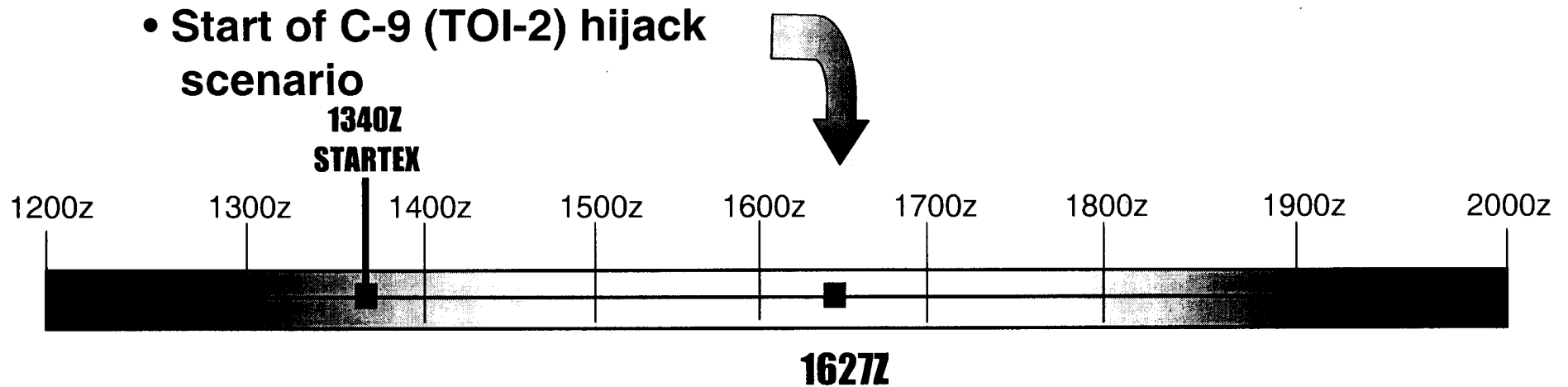

- Initial report: Emergency Mode III 7700, 100nm East of Seattle
- WADS commit Great Falls F-16s. However, FAA stated that no assistance was required
- At 1630Z the C-9 (TOI-2) deviated from the filed flight plan
 - A hijacker was reported in the cockpit
 - The hijackers declare their destination as Canada

AV02

- CANR DO directs Comox CF-18s to split the flight

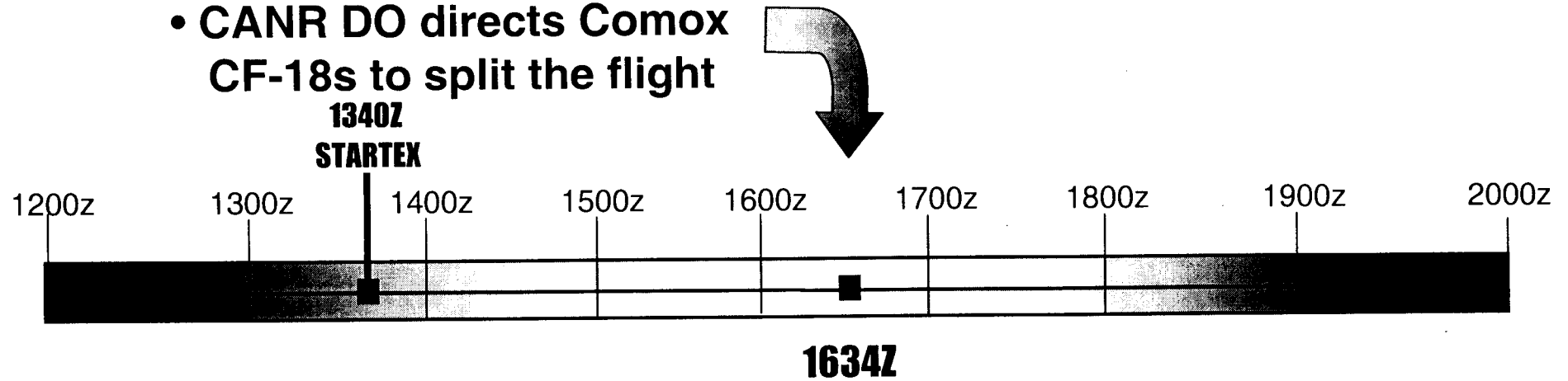

- 1 will escort the Delta 757 (TOI-1)
- 1 will escort the C-9 (TOI-2)
- Although the CANR DO directed the flight to split, the split never occurred

AV02

- Delta 757 (TOI-1)
Enters Canadian Airspace

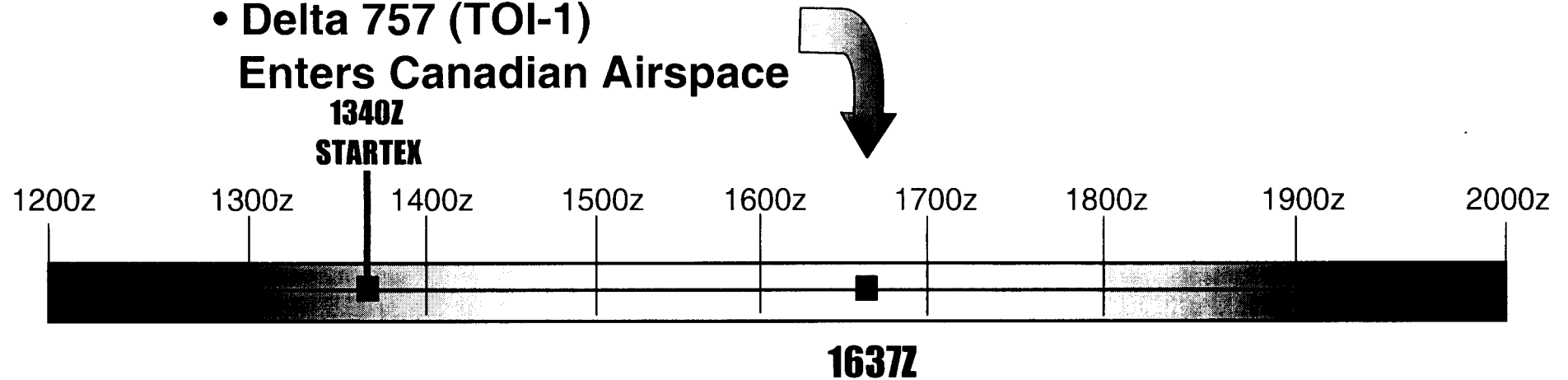

- Comox fighters assumed escort responsibility

AV02

- **Great Falls F-16s Intercept C-9 (TOI-2)**

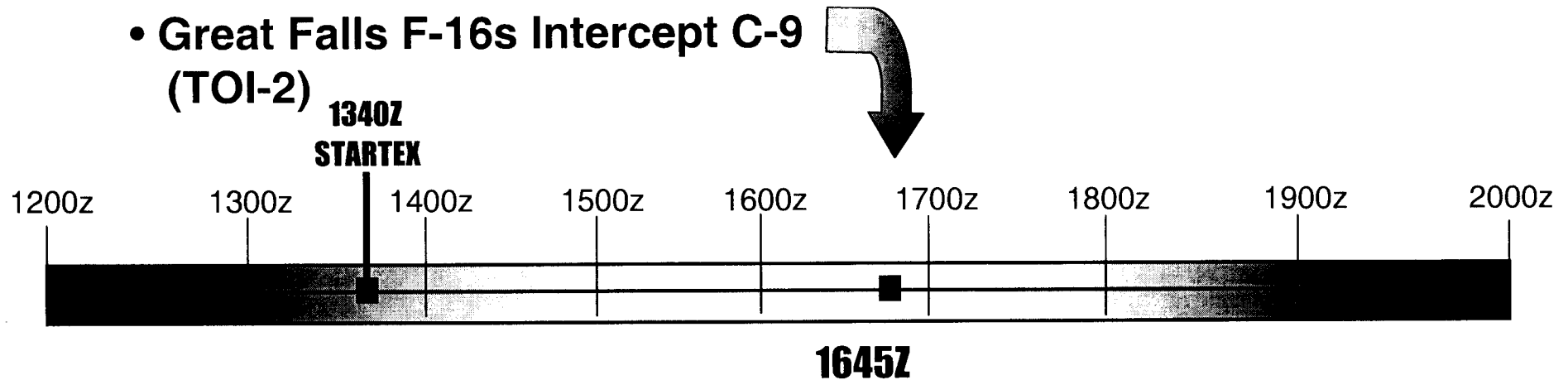

- **Comox CF-18s remain on Delta 757 (TOI-1)**
- **Sim CINCNORAD pre-approved cross border for Great Falls F-16s**

AV02

- **Great Falls F-16s Handoff to CANR/CADS**

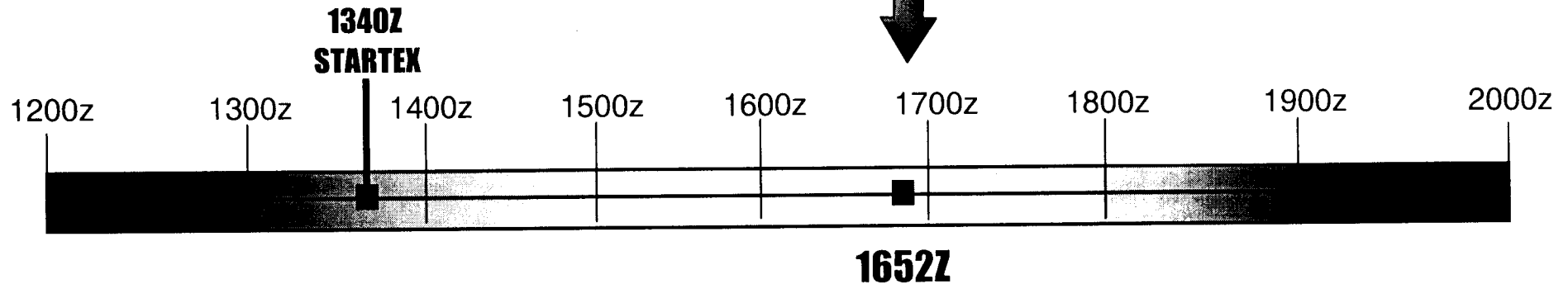

- **CANR DO directs the divert of the C-9 (TOI-2) to Kelowna**
- **At 1657Z Sim CINCNORAD reaffirmed the use of U.S. fighters in Canadian airspace**
 - **Engagement not authorized without approval of Canadian Government**

AV02

- One CF-18 Leaves Delta 757 (TOI-1)

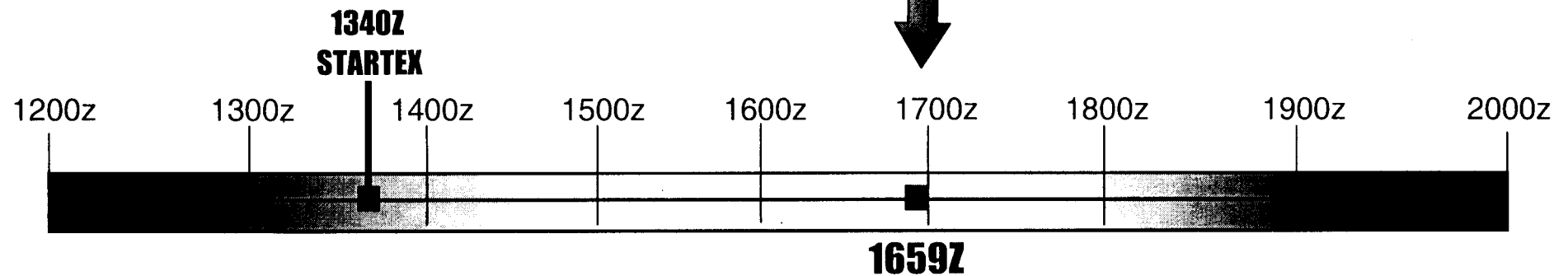

- One Comox CF-18 leaves the Delta 757 (TOI-1) due to low fuel
- The other CF-18 remains with the Delta TOI

AV02

- C-9 (TOI-2) enters Canadian airspace

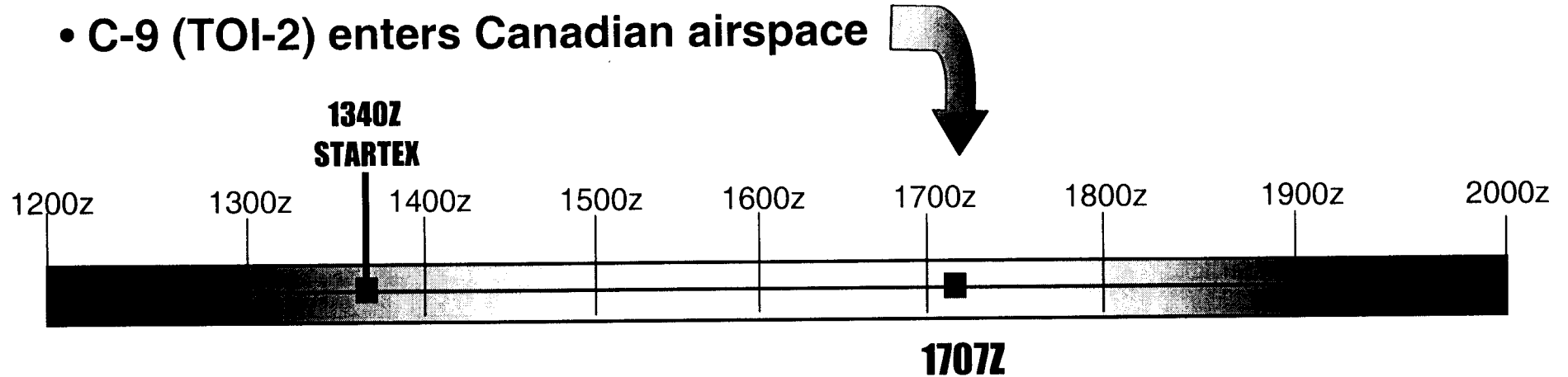

- The remaining Comox CF-18 leaves the Delta 757 (TOI-1) due to low fuel at 1708Z
- ANR F-15s are 500+ miles out from the Delta TOI

AV02

- FBI reports the Delta 757 (TOI-1) enroute to Anchorage

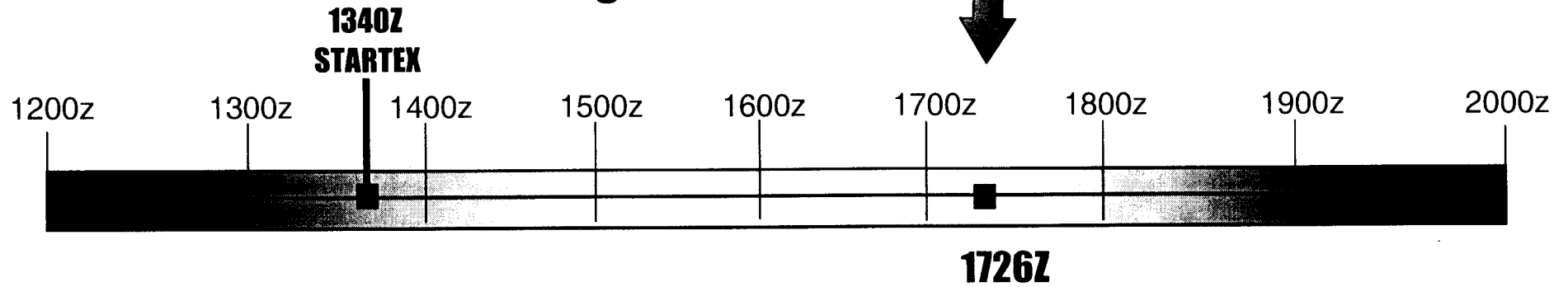

AV02

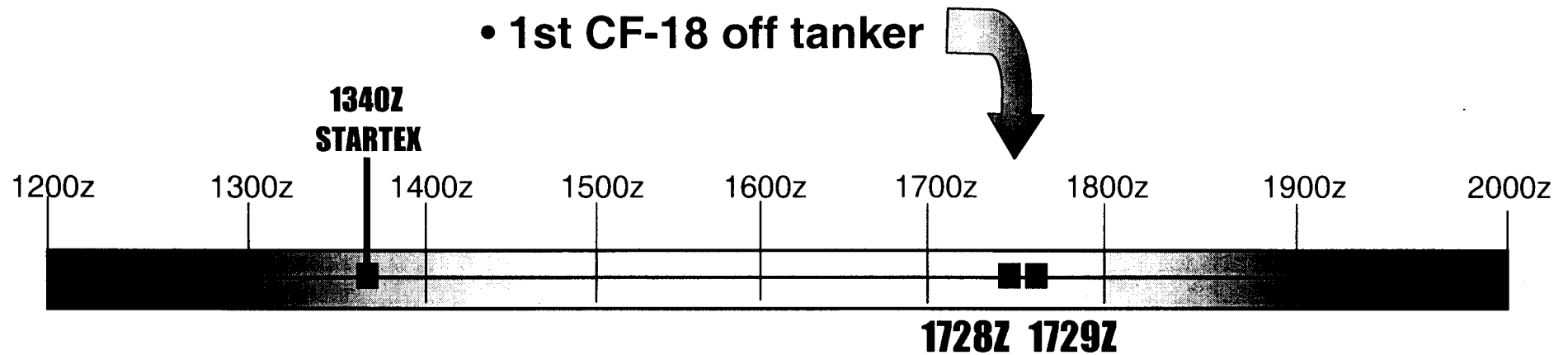

- 1st CF-18 off tanker
- CF-18's are directed to intercept C-9 (TOI-2)
- Hijackers request to land at Vancouver

- Delta 757 (TOI-1) In ANR E-3 Coverage
- ANR F-15s given approval for overt intercept on TOI-1, ETI 1756

AV02

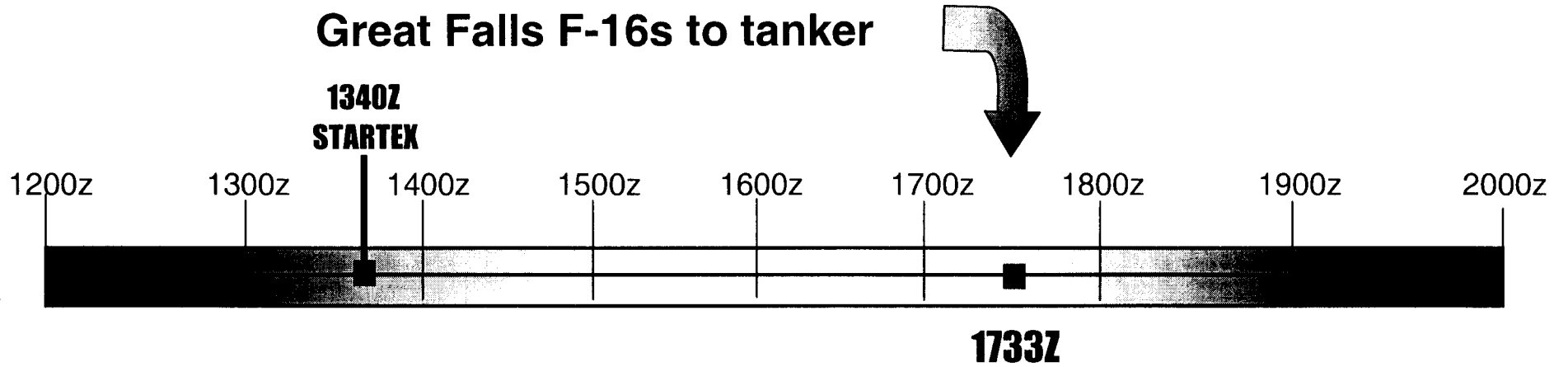

- Comox takes over intercept of C-9 (TOI-2) at 1735Z

AV02

- Valdez designated High Value Target

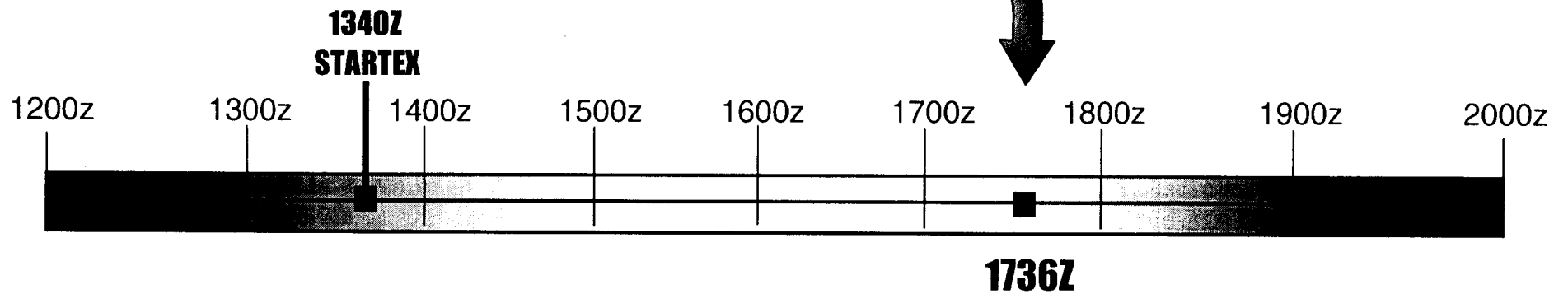

- The Delta 757 (TOI-1) is 600+ miles from Valdez

AV02

- CANR issues landing instructions for C-9 (TOI-2)

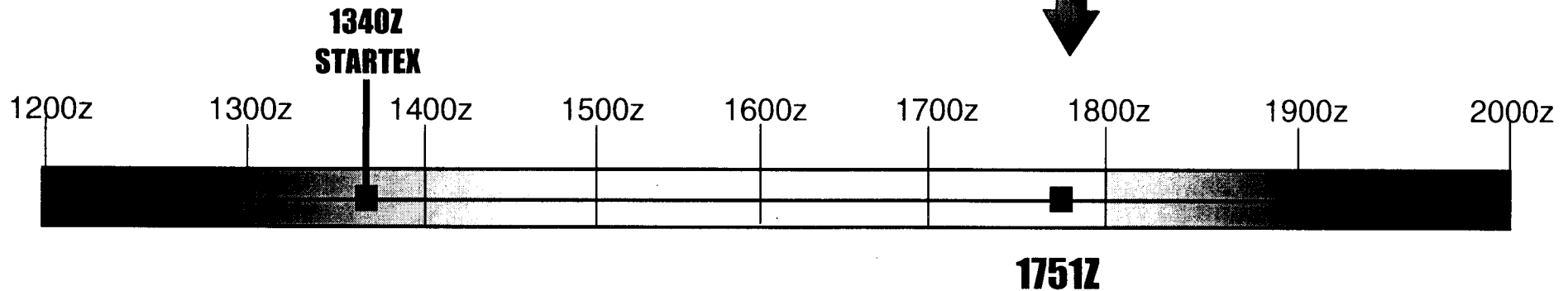

- To land at Vancouver, the following criteria must be met:
 - Be in landing configuration 60 miles out, 40 miles minimum
 - CF-18s will escort to landing

AV02

- ANR F-15s VID Delta 757 (TOI-1)

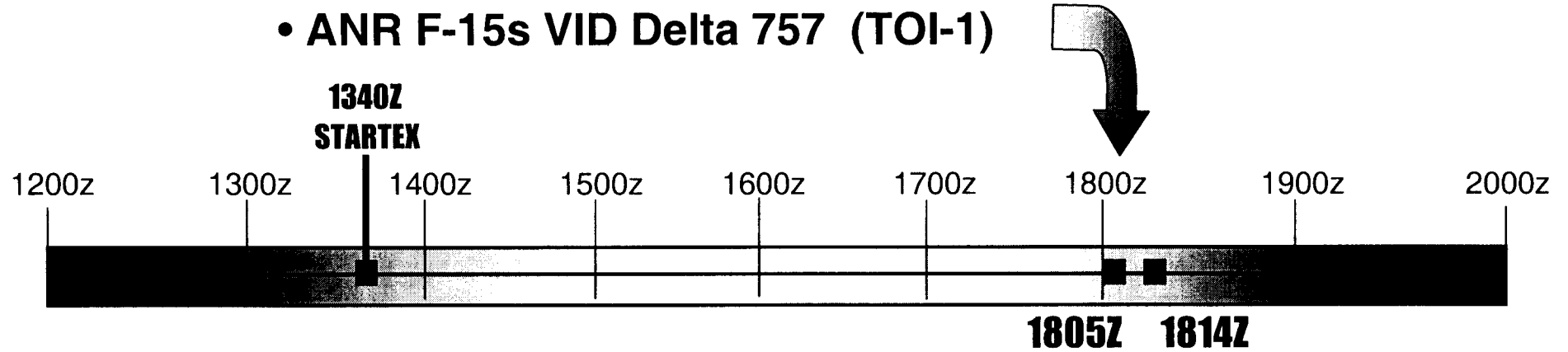

- RCMP supports C-9 (TOI-2) request to land at Vancouver

AV02

- Delta 757 (TOI-1) Diverting to Elmendorf AFB

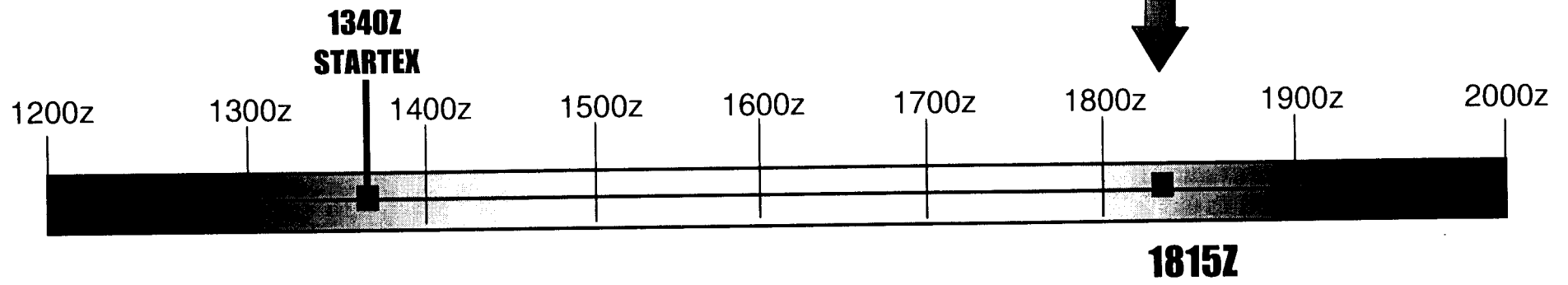

AV02

- C-9 (TOI-2) in landing configuration

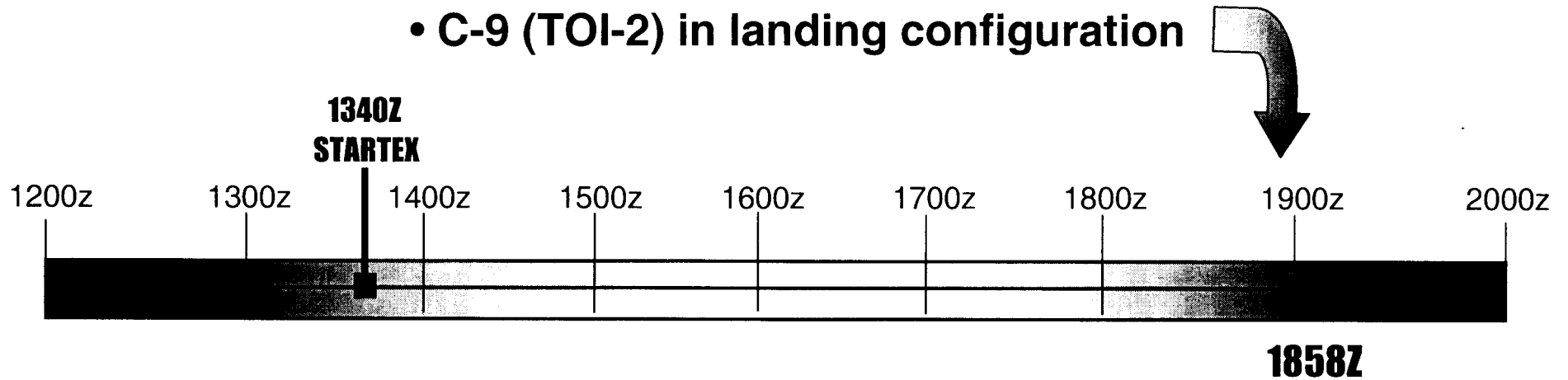

- Meet all engagement parameters except heading toward downtown Vancouver

AV02

• C-9 (TOI-2) Lands at Vancouver

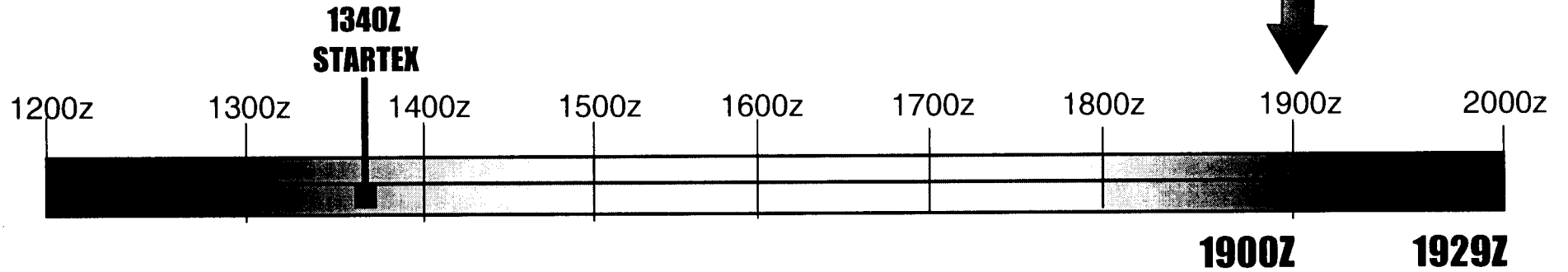

• Delta 757 (TOI-1) Lands at Elmendorf, ENDEX Air Portion

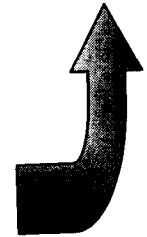

AV02

PRE-PLANNED OBSERVATIONS

- **Noble Eagle Domestic Event / Threat Conferencing**
 - **Appropriately initiated**
 - **Convened in a timely manner**
 - **Problems**
 - **Conferees**
 - **Discipline**

- **Rules of Engagement**
 - **Clearly understood Hostile & Engagement Authority**
 - **CANR outlined detailed engagement parameters**

AV02

PRE-PLANNED OBSERVATIONS

- **Pre/Post Hijack Procedures**
 - **Pre 9/11 Hijack Procedures**
 - **Hijack Conference**
 - **FAA Military Assist Request**
 - **Checklist**

- **Interagency Coordination**
 - **Exercise enabled “play” and coordination among and between numerous Canadian and US agencies**
 - **RCMP, FBI, FAA, NAVCAN, NRC, FEMA ...**

AV02

OTHER OBSERVATIONS

- **OPREP 3 Reporting**
- **NORAD Form 61 Track Report**
- **Forward Tell**
- **Common Operating Picture (COP)**
- **Red Switch**
- **CMOC ABMO Overload**

AV02

OTHER OBSERVATIONS cont.

- **Callsigns: Real verses Exercise**
- **Exercise Video**

AV02

Proposed JULLS

- **OPREP-3 Processing**
- **Pre & Post 9/11 Hijack Procedures**
- **Noble Eagle DEC/DTC Conference Discipline**
- **Exercise vs. Real World Callsign Use**
- **Red Switch**
- **CMOC ABMO Overload**
- **Add NAVCAN to 24/7**

AMALGAM VIRGO 02

TECHNICAL STUDIES AND ANALYSIS CORP

25 JUNE 2002

BRIEFER: CARL HOWELL

THIS BRIEFING IS

UNCLASSIFIED